

# TEST REPORT

## Laboratory measurement of sound absorption of Acupanels Træ Panels – Type E-65 mounting

### Performed for Fog & Venø A/S

Project no.: 122-32087

DANAK no. 100/2800 Revision 1

Page 1 of 14

Hørsholm, 11 November 2022



### Acoustics, Noise and Vibrations

Reviewed by

**Rasmus Stahlfest Holck Skov**  
2022-11-11

Digitally signed by Rasmus Stahlfest Holck Skov  
rshs@forcetechnology.com  
Specialist

Reported by

**Liisa Sell**

2022-11-11

Digitally signed by Liisa Sell  
liis@forcetechnology.com  
Specialist

# OVERVIEW

<b>Title</b>	Laboratory measurement of sound absorption of Acupanels Træ Panels – Type E-65 mounting
<b>Project no.</b>	122-32087
<b>DANAK no.</b>	100/2800 Revision 1
<b>Test period</b>	13 October 2022
<b>Client</b>	Fog & Venø A/S Buntmagervej 5 7490 Aulum Denmark E-mail: hello@fog-veno.com Tel.: +45 88 77 83 70
<b>Contact person</b>	Anders Dahlgaard E-mail: ad@fog-veno.com
<b>Test method</b>	Test method: EN ISO 354:2003 Evaluation: EN ISO 11654:1997 Uncertainty: EN ISO 12999-2:2020
<b>Summary</b>	Laboratory measurements of sound absorption coefficients were carried out in a reverberation room according to the test method of EN ISO 354:2003. Product: Acupanels Træ Panels Mounting: Type E-65 with mineral wool The test results per one-third octave are shown in tabular form and graphically on Graph Sheet 1. Descriptions of reverberation room and test procedure are found in Appendix 4.

**Revisions**

This test report replaces previously issued DANAK test report 100-2800 dated 8 November 2022. The changes in this revision are: The client name and address has been changed from Acupanels International ApS to Fog & Venø A/S.

---

**Test site**

DTU, Akademivej, Bygning 355, 2800 Kongens Lyngby, Denmark

---

**Our ref.**

LISL/RSHS/ilk

---

DANAK is the national accreditation body in Denmark in compliance with EU regulation No. 765/2008.

DANAK participates in the multilateral agreements for testing under European co-operation for Accreditation (EA) and under International Laboratory Accreditation Cooperation (ILAC) based on peer-evaluation. Accredited test reports issued by laboratories accredited by DANAK are recognized cross border by members of EA and ILAC equal to test reports issued by these members' accredited laboratories.

The use of the accreditation mark on test reports documents that the service is provided as an accredited service under DANAK accreditation.

FORCE Technology is accredited by DANAK, reg. no 100.

The test results only relate to the items tested.

This report is only valid with two digital signatures from FORCE Technology. The original version of the report is archived in FORCE Technology's database and is sent in electronic duplicate to the customer. The stored version of the report at FORCE Technology prevails as documentation for its contents and validity.

This report must not be reproduced, except in full, without the written approval of FORCE Technology.

---

# TABLE OF CONTENTS

<b>1</b>	<b>Introduction .....</b>	<b>5</b>
<b>2</b>	<b>Description of the test specimen based on the client's specifications .....</b>	<b>5</b>
<b>3</b>	<b>Mounting in the laboratory .....</b>	<b>5</b>
<b>4</b>	<b>Test method .....</b>	<b>5</b>
<b>5</b>	<b>Measurement conditions .....</b>	<b>6</b>
<b>6</b>	<b>Test results .....</b>	<b>6</b>
<b>7</b>	<b>Measurement uncertainty .....</b>	<b>7</b>
<b>Appendix 1</b>	<b>Graph Sheets.....</b>	<b>8</b>
<b>Appendix 2</b>	<b>List of instruments .....</b>	<b>11</b>
<b>Appendix 3</b>	<b>Photo and drawing.....</b>	<b>12</b>
<b>Appendix 4</b>	<b>Description of reverberation room and test procedure .....</b>	<b>14</b>

## 1 Introduction

At the request of Fog & Venø A/S, measurements of sound absorption coefficients in a reverberation room have been carried out for Acupanels Træ Panel product.

## 2 Description of the test specimen based on the client's specifications

Acupanels Træ Panel is an acoustic panel of polyester felt that is covered with plywood lamellas.

Product:	Acupanels Træ Panel
Lamellas:	27 x 11 mm plywood from MDF and wood veneer, 12 mm spacing between lamellas
Felt:	9 mm polyester felt
Thickness:	9 mm polyester felt / 20 mm felt with lamellas
Insulation:	45 mm mineral wool, density 16 kg/m <sup>3</sup> , placed between 45 x 45 mm wooden battens of 600 mm spacing
Construction height:	65 mm
Module size:	Different sizes.

## 3 Mounting in the laboratory

The panels were placed as a plane on a concrete floor in a frame with the size 3.60 m × 3.00 m on top of a 45 mm mineral wool layer. The mineral wool was placed between 45 x 45 mm wooden battens of 600 mm spacing.

Mounting depth: 65 mm (Type E-65 mounting).

Both the mineral wool layer and the edges of the test specimen were enclosed by a wooden frame.

All joints between the test specimen and the frame as well as between the frame and the concrete floor were sealed with tape.

The test sample was placed so that no part of them was closer than 1 m to any edge of the boundary of the room other than the floor.

The photo and drawing of the test specimen in the laboratory can be seen in Appendix 3.

## 4 Test method

The measurements were carried out according to the test method of ISO 354:2003: "Measurement of Sound Absorption in a Reverberation Room".

The test specimen was put together of 5 Træ panels of size 2400 x 600 mm and 5 Træ panels of size 1200 x 600 mm to form a test area of 10.8 m<sup>2</sup> (3.0 x 3.6 m).

The sound absorption coefficient was calculated from the reverberation times measured with and without the test specimen.

The measurements were performed in Room 005, Building 355 at the Technical University of Denmark. Brief descriptions of the reverberation room and test procedure are found in Appendix 4.

## 5 Measurement conditions

The reverberation time was recorded in 6 microphone positions, each placed in the range 1.55 m to 2.85 m above the floor. The number of sound source positions was two.

The reverberation time  $T_1$  per third octave of the room without test specimen and the reverberation time  $T_2$  per third octave of the room with test specimen:

Frequency [Hz]	Reverberation Time $T_1$ [sec]	Reverberation Time $T_2$ [sec]
100	6.30	5.31
125	7.63	5.05
160	7.73	4.47
200	7.43	3.35
250	7.02	3.17
315	7.40	2.46
400	6.68	2.19
500	6.22	2.16
630	6.24	2.16
800	5.80	2.04
1000	5.22	1.97
1250	4.95	2.06
1600	4.63	2.01
2000	4.16	1.96
2500	3.76	1.95
3150	2.96	1.70
4000	2.42	1.54
5000	2.06	1.43

Temperature and relative humidity in the reverberation room during measurements:

Measurement	Date	Temperature, °C	RH, %
Without specimen	13 October 2022	18.2	57.0
With specimen	13 October 2022	18.3	58.7

The correction of the absorption coefficient due to differences in temperature and relative humidity during measurements of  $T_1$  (the reverberation time of the empty room) and  $T_2$  (the reverberation time of the room with test specimen) was 0 at all frequencies.

## 6 Test results

The test results – the sound absorption coefficient  $\alpha_s$  per one-third octave from 100 Hz to 5000 Hz are shown in tabular form and graphically on Graph Sheet 1.

The calculated practical sound absorption coefficient  $\alpha_p$  per octave from 125 Hz to 4000 Hz is shown in tabular form and graphically on Graph Sheet 2, together with the weighted absorption coefficient  $\alpha_w$  and the associated absorption class. These numbers are calculated according to ISO 11654:1997.

## 7 Measurement uncertainty

The measurement uncertainty for the sound absorption coefficient  $\alpha_s$  per object per one-third octave,  $\alpha_p$  per octave and the weighted absorption coefficient  $\alpha_w$  is calculated according to EN ISO 12999-2:2020. The expanded uncertainty U given as a two-sided 95 % confidence interval (k=2) based on the reproducibility is as follows:

$\alpha_s$		$\alpha_p$		$\alpha_w$
Frequency [Hz]	U (k=2)	Frequency [Hz]	U (k=2)	U (k=2)
100	±0.08	250	±0.10	±0.07
125	±0.10	500	±0.08	
160	±0.12	1000	±0.08	
200	±0.14	2000	±0.08	
250	±0.14	4000	±0.10	
315	±0.16			
400	±0.14			
500	±0.12			
630	±0.12			
800	±0.12			
1000	±0.12			
1250	±0.10			
1600	±0.10			
2000	±0.10			
2500	±0.10			
3150	±0.12			
4000	±0.12			
5000	±0.16			

# Appendix 1

# Graph Sheets





# Laboratory measurement of sound absorption according to EN ISO 354:2003

Client: Fog & Venø A/S, Buntmagervej 5, 7490 Aulum, Denmark

Date of test: 13 October 2022

Test specimen: Product: Acupanels Træ Panel

Thickness: 20 mm

Construction height: 65 mm (Type E-65 mounting with mineral wool)

Test area: 10.8 m<sup>2</sup>

Room volume: 215 m<sup>3</sup>

Room surface: 305 m<sup>2</sup>

Frequency f [Hz]	$\alpha_s$
100	0.09
125	0.22
160	0.30
200	0.53
250	0.56
315	0.87
400	0.99
500	0.97
630	0.97
800	1.02
1000	1.02
1250	0.91
1600	0.90
2000	0.87
2500	0.80
3150	0.81
4000	0.77
5000	0.71

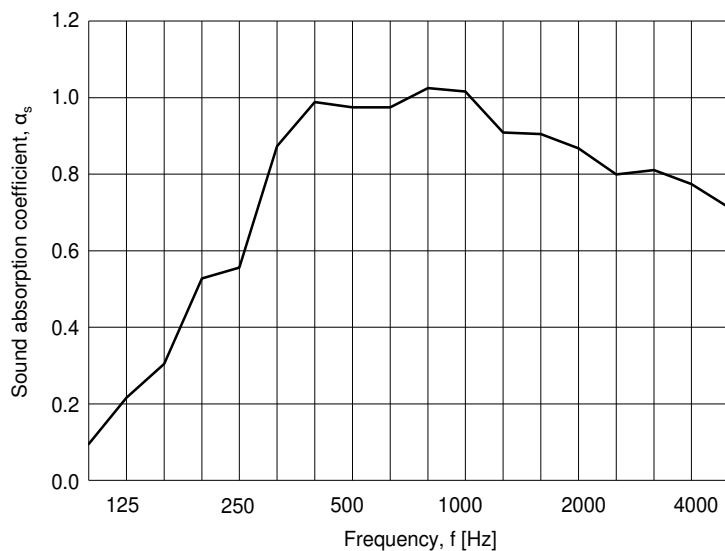

FORCE Technology, 10 November 2022

Liisa Sell  
Acoustics, Noise and Vibrations

## Laboratory measurement of sound absorption according to EN ISO 354:2003

Client: Fog & Venø A/S, Buntmagervej 5, 7490 Aulum, Denmark

Date of test: 13 October 2022

Test specimen: Product: Acupanels Træ Panel

Thickness: 20 mm

Construction height: 65 mm (Type E-65 mounting with mineral wool)

Test area: 10.8 m<sup>2</sup>

Room volume: 215 m<sup>3</sup>

Room surface: 305 m<sup>2</sup>

Frequency f [Hz]	$\alpha_p$
125	0.20
250	0.65
500	1.00
1000	1.00
2000	0.85
4000	0.75

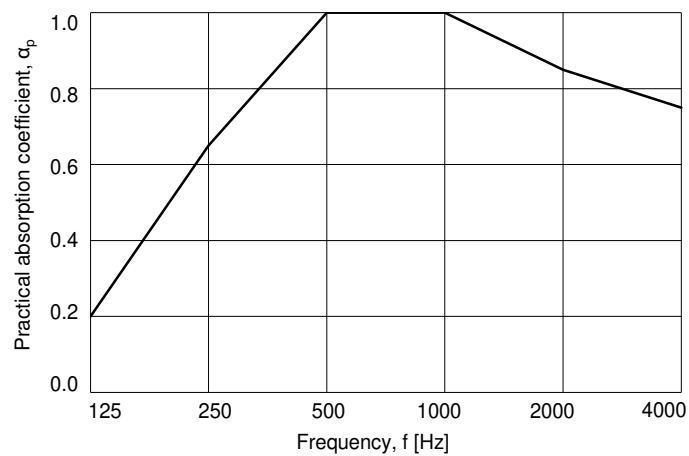

Practical absorption coefficient, weighted absorption coefficient and absorption class according to EN ISO 11654:1997:

$$\alpha_w = 0.85$$

Absorption class: B

FORCE Technology, 10 November 2022

Liisa Sell

Acoustics, Noise and Vibrations

## Appendix 2 List of instruments

No.	Equipment	Producer	Model	Calibration Latest	Calibration Next
1498L	Sound Level Meter/ Analyzer	Brüel & Kjær	2270	2021-09-02	2023-09-02
1256L	Measuring microphone	Brüel & Kjær	4144	2022-02-25	2024-02-25
1616L	Measuring microphone	GRAS	40EN	2022-07-13	2024-07-13
853L	Microphone preamplifier	Brüel & Kjær	2619	2022-02-25	2024-02-25
1395L	Microphone preamplifier	Brüel & Kjær	2619	2022-07-08	2024-07-08
1040L	Microphone power supply	Brüel & Kjær	5935	2022-07-12	2024-07-12
1654L	Sensor for tempera- ture and humidity	Rotronic Instruments	BL-1D-SET	2021-05-18	2023-01-01
1158L	Acoustic calibrator	Brüel & Kjær	4231	2022-06-07	2022-12-07

## Appendix 3 Photo and drawing



**Figure 1** *Acupanel Træ Panels mounted in the laboratory (Type E-65 mounting).*

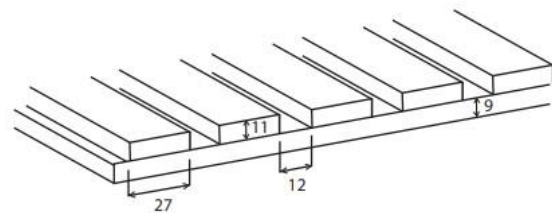
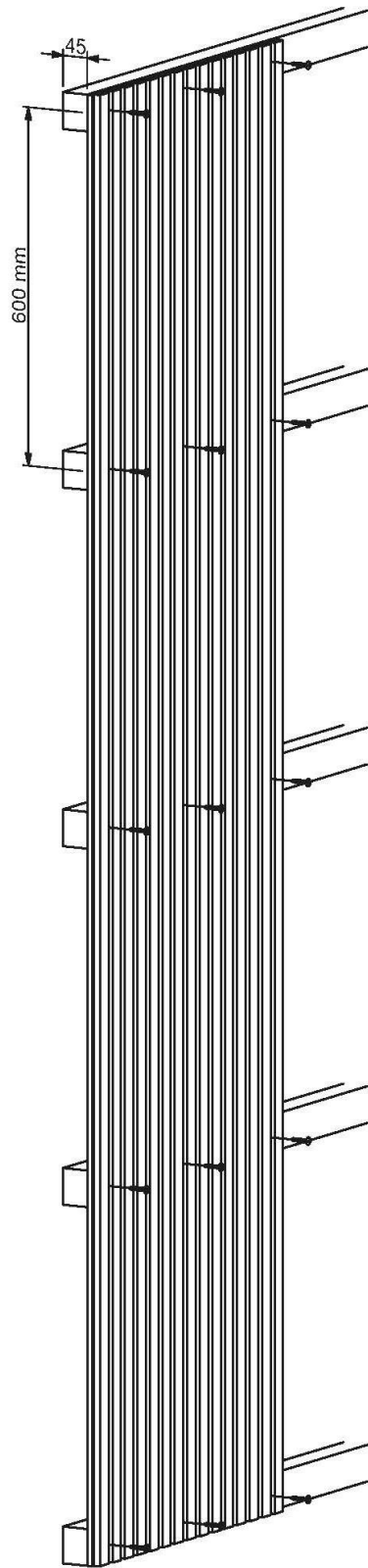

**Figure 2** Drawing of Acupanel Træ Panels.

## Appendix 4 Description of reverberation room and test procedure

### Reverberation room

The measurements are performed in a reverberation room (Room 005, Building 355 at the Technical University of Denmark) with walls, ceiling, and floor of 300 mm in situ cast concrete. Length, width, and height of the room are 7.85 m, 6.25 m, and 4.95 m, respectively. The volume of the room is approx. 215 m<sup>3</sup>, and the total surface area is approx. 305 m<sup>2</sup>. Sound diffusion elements of concrete, of damped steel plate, and of acrylic sheets are placed in the room.

### Test procedure

Measurement of sound absorption according to EN ISO 354:2003 is carried out in a reverberation room. The reverberation time is measured with and without the test specimen, and the sound absorption coefficient is evaluated using Sabine's formula.

The test signal used is broad band pink noise emitted successively by two loudspeakers located in two opposite corners of the room. The reverberation time is measured in six microphone positions for each loudspeaker. For each microphone/loudspeaker position three repeated excitations are used. One-third octave filters (100-5000 Hz) are included in the receiving equipment.

The reverberation time is evaluated from the averaged slope of the decay curve over a range from 5 dB to 25 dB below the steady state level.

The sound absorption coefficient  $\alpha_s$  is calculated using the following formula:

$$\alpha_s = \frac{55,3 \cdot V}{S} \cdot \left( \frac{1}{c_2 \cdot T_2} - \frac{1}{c_1 \cdot T_1} \right) - \frac{4V}{S} \cdot (m_2 - m_1)$$

Where

- $\alpha_s$  = Sound absorption coefficient
- V = Volume of the empty reverberation room [m<sup>3</sup>]
- S = Area of the test specimen
- $c_1$  = Velocity of sound in air [m/s] without test specimen
- $c_2$  = Velocity of sound in air [m/s] with test specimen
- $T_1$  = Reverberation time of the empty reverberation room [s]
- $T_2$  = Reverberation time of the reverberation room after the test specimen has been introduced [s]
- $m_1$  = Attenuation coefficients due to air absorption during measurement of  $T_1$  (m<sup>-1</sup>)
- $m_2$  = Attenuation coefficients due to air absorption during measurement of  $T_2$  (m<sup>-1</sup>)

The attenuation coefficient of sound in air varies with relative humidity, temperature, and frequency. During a series of measurements of reverberation times  $T_1$  and  $T_2$ , the relative humidity and the temperature are held as constant as possible. A correction term as given in the formula above is applied. The correction is based on data from ISO 9613-1:1993.